

**OPERATING INSTRUCTIONS
AND PARTS LIST
AUTOMATIC FILLING MACHINE
DE-401-GB-AUTO**



ADCENG GAS EQUIPMENT (PTY) LTD

www.adceng.co.za

P O BOX 5413, JOHANNESBURG 2000

Phone: 011 493-8209

Fax: 011 493-1459

Email: adceng@mweb.co.za

P O BOX 83, PAARDEN EILAND 7420

Phone: 021 511-6671

Fax: 021 511-4891

Email: adcct@mweb.co.za

P O BOX 74225, ROCHDALE 4034

Phone: 031 579-1555

Fax: 031 579-1563

Email: adcdbn@mweb.co.za

AUTOMATIC LPG FILLING MACHINE FOR SMALL CONTAINERS **MODEL DE-401-GB-AUTO**

GENERAL

The filling unit as shown on the attached drawing is intended for retail outlets and other similar LP-Gas filling sites which fill small containers up to 9 Kg capacity. All the equipment incorporated in this unit is approved for liquid LP-Gas service and meets the requirements of SABS Specification SANS 10087 Part 7 as amended. The installation has to be made according to this code of practice.

The small platform scale is Assize-approved, and of robust construction to withstand the weighing and filling of steel containers under working conditions. The scale has been specially prepared for filling of gas containers. It will ensure the filling of these small containers to within a close margin of the allowable filling mass, provided that the filling operation is carried out by a properly trained person.

No allowance will have to be made for the mass of the filling hose and valve, by setting the scale at zero whilst the hose and quick acting valve are resting on the platform of the scale. The hose must be full of gas up to the quick-acting valve (1) when doing the setting.

SPECIAL DESIGN FEATURES OF THE 401DE PUMP INCORPORATED **IN THIS MODEL FILLING MACHINE DE-401-GB-AUTO**

The electric piston pump has been developed with a view to overcoming the problems usually encountered with high revving centrifugal gear or vane pumps, when they are used for filling of small containers from upright 48 Kg LPG supply containers. This pump is able to cope with vapour locks which are encountered in this type of operation and will not be ruined when it runs dry for a reasonable length of time, e.g. when the 48 Kg supply vessel is empty. This is achieved by the use of a special type of piston fitted with a Fluorosint piston ring operating in a cylinder. The pump is also equipped with an external by-pass arrangement which protects it against over-pressure when pumping against blocked or very restricted container valves. The by-pass valve is set to open at a differential pressure of 80 psi (550 kPa) and should not be altered, otherwise the electric motor might become overloaded and could stop.

OPTIONAL EQUIPMENT

Withdrawal with this pump can be made from a single 48 Kg liquid supply vessel. We would, however, recommend the withdrawal from a two-vessel manifold.

FILLING TIMES

Whilst the capacity of this pump is approximately 6 litres/min the filling times which are achieved will depend to a large extent on the make and type of container to be filled, i.e. on the restriction offered by the container valve. Experience has shown that a 4,5 Kg cylinder is filled in 2 – 3 minutes.

FLAMEPROOF MOTOR AND ELECTRICS

The electric motor supplied with this pump is a flameproof type, to SABS 314-1971 suitable for the requirements of SABS-0108 Class 1, Division 1. The motor can be operated from a normal 220-240 volt AC, single phase, 15 amp electric mains supply provided that the point of supply (electrical socket) is not within the hazardous area (defined in SANS 10087 Part 7). The motor and connections comply with SABS 1031-1976 "Type e" – apparatus for use in explosive gas atmosphere.

The intrinsically safe proximity sensors meet SABS Code 549 and the flameproof control module with switches are certified by the SABS Test House to meet SABS 314-1971. The pump motor is supplied with a 10m length of PVC CABTYRE electrical cable which has already been connected to the motor by means of a flameproof cable box. The connections at the motor should not be tampered with or the cable box opened, as this might render the sealing compound and cable box ineffective and the connection would become non-flameproof. This could have dangerous results. It is necessary that a longer cable than 10m be used, the extra length of PVC CABTYRE cable must be connected to the existing 10m cable by means of a flameproof connection box (PRATLEY) which is necessary if the connection is within the hazardous area. Otherwise if the connection is outside the hazardous area, it can be made in the normal way and insulated accordingly. If the cable is damaged in any way it must be replaced immediately.

MAINTENANCE

1. The Y-strainer must be inspected and cleaned out if necessary, after approximately every 10 x 48 Kg supply containers have been used up. If the strainer is clogged, it will obviously affect the efficiency of the pump. Before opening the strainer, make sure that all the pipe work has been vented, i.e. no gas is present in the hoses or pipes. Then remove the large nut on the strainer and take out the wire mesh inside to check for dirt. Clean if necessary.
2. The design of the pump unit is such that it will give very reliable service in normal use. If, however, the pump unit (cylinder, piston and by-pass) is suspected of being faulty in any way, we suggest that the unit be removed and returned to ADCENG preferably in the assembled condition. The unit can be taken out by removing the bolt which attaches the piston rod to the cam, and removing the bolt at the bottom of the assembly on which the body swivels.

Upright liquid withdrawal industrial-type cylinders only must be utilised.

(DO NOT UP-END VAPOUR CYLINDERS AS IT WILL SHORTEN PUMP LIFE AS WELL AS BEING A POTENTIALLY DANGEROUS PRACTICE)

OPERATING INSTRUCTIONS FOR DE-401-GB-AUTO

A SUITABLY TRAINED OPERATOR MUST ALWAYS BE PRESENT DURING THE FILLING OPERATION

- A. Connect the inlet hose flare nut (2) to the liquid outlet of the supply container valve (duo valve). Do not open the inlet valve yet.
- B. Open ball valve (3) on inlet hose.
- C. Ensure that the filling hose up to the quick acting valve (1) is filled with liquid before venting the air out of the hose. Now place the hose and quick acting valve on the platform of the scale. The beam (2) should be in equilibrium with the sliding weight (3) at zero.
- D. If the scale is not in equilibrium, turn the screw (4) at the back of the beam in or out using a screw-driver. This will adjust the beam to the required position.
- E. Place the small cylinder to be filled on the scale platform and connect the quick acting valve (1) to the small container valve. Use the appropriate filling adapters to suit the cylinder being filled.
- F. Calculate the appropriate filling mass, i.e. (tare mass plus container capacity) and set the weight on the carrier (5) of the scale.
- G. Open the ball valve (6) the small container valve and quick acting valve (1).
- H. Open liquid filling supply container valve (red handle on duo valve) slowly to prevent closing of excess flow valve inside the supply container. Liquid will now flow through the inlet hose into the hand pump and the small container until the pressure between the two containers is equalized. Should the excess flow valve snap shut (indicated by an audible click) it must be released by re-closing the supply container and waiting for a few second until another click is heard. The supply valve must then be opened just slightly until the initial rush of liquid through it is heard to slow down after which it may slowly be fully opened. When the pressure begins to equalize the flow of liquid will be heard to slow down.
- I. Press start button to operate pump when correct filling mass has been reached. The beam will move up which will activate the proximity switch which will automatically switch the pump off. Shut off quick acting valve (1).
- J. Close the small container valve and disconnect the quick acting valve (1) from the small cylinder which is now full.
- K. If cylinder filling operations are complete then close the liquid withdrawal valve (red). Do not close the ball valve until the supply container is to be removed.

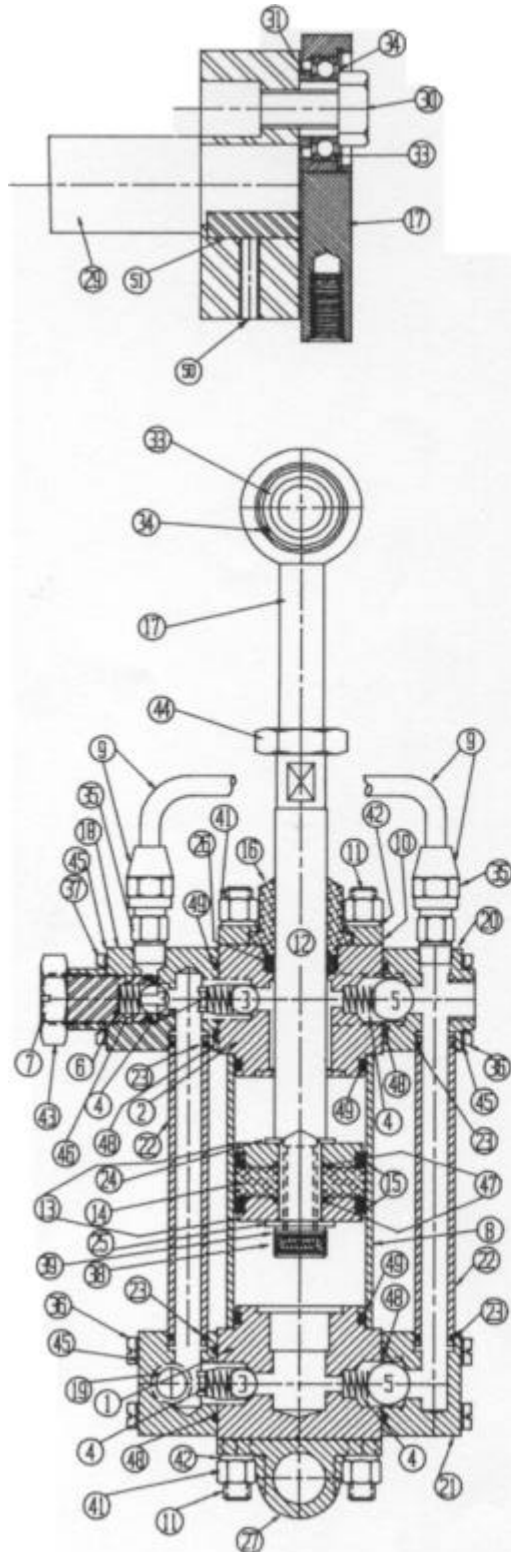

ITEM	QTY.	DESCRIPTION	PART No.	ORG. N°
1	1	LOWER CYLINDER BLOCK	ZAPP-401-DE501	P401298A
2	1	UPPER CYLINDER BLOCK	ZAPP-401-DE502	P401300A
3	3	OUTLET & RELIEF VALVE BALL	ZAPP-10101-011	
4	4	BRONZE VALVE SPRING	ZAPP-101-014	
5	2	INTAKE VALVE BALL	ZAPP-101-015	
6	1	RELIEF VALVE SPRING	ZAPP-10401-004	
7	1	RELIEF VALVE PLUG	ZAPP-401-DE503	P401249A
8	1	CYLINDER	ZAPP-0494-401-DE-504	P401530B
9	1	BY-PASS TUBE ASSEMBLY	ZAPP-401-DE505	P401590A
10	1	GUIDE-BUSH RETAINING CAP	ZAPP-401-506	P401670D
11	4	TIE ROD	ZAPP-401-573	P401500A
12	1	PISTON ROD	ZAPP-401-508M	P401770D
13	2	BRASS PISTON DISC	ZAPP-401-508D	
14	1	MESCONITE PISTON DISC	ZAPP-401-508N	P401178A
15	2	"FORSEAL" PISTON SEAL	ZAPP-401-508U	P401590A
16	1	PISTON-ROD GUIDE BUSH	ZAPP-401-DE-510	P401168A
17	1	CONNECTING-ROD/SEARING HOUSING	ZAPP-401-510M	P401436A
18	1	UPPER OUTLET AND RELIEF VALVE BLOCK	ZAPP-401-512A	P401398A
19	1	LOWER OUTLET VALVE BLOCK	ZAPP-401-512B	P401340A
20	1	UPPER INTAKE VALVE BLOCK	ZAPP-401-513A	P401310A
21	1	LOWER INTAKE VALVE BLOCK	ZAPP-401-513B	P401390A
22	2	VALVE-BLOCK CONNECTING TUBE	ZAPP-LONG-401-514	P401910D
23	4	O-RING CONNECTING TUBES	ZAPP-401-515	
24	1	PISTON WASHER 13 x 2 (PRECISION)	ZAPP-401-516	
25	1	PISTON WASHER 10 x 1,6 (GALV)	ZAPP-401-517	
26	1	"FORSEAL" PISTON-ROD SEAL	ZAPP-401-518U	
27	1	TRAMOLON	ZAPP-401-520	P401218A
28	1	CONNECTING CAM FOR GEAR BOX	ZAPP-10401-CAM	P401000A
29	1	GEAR BOX SHAFT	ZAPP-10401-SHAFT	P401590A
30	1	CRANK PIN	ZAPP-10401-044M	P401418A
31	1	CRANK PIN SPACER BUSH	ZAPP-10401-046	P401468A
32	1	SPECIAL WASHER: CRANK PULLEY BELT	ZAPP-10401-048	
33	1	CRANK BEARING	ZAPP-401-6203-ZZ	
34	1	COUPLER; RETAINING CRANK BEARING	ZAPP-472-409M	
35	2	BY-PASS TUBE NIPPLE	ZAPP-40-4	
36	4	VALVE-BLOCK SECURING BOLT	ZAPP-401-DEH-5 X 30	
37	4	RELIEF-VALVE BLOCK SECURING BOLT	ZAPP-401-DEH-5 X 40	
38	1	PISTON CAP-SCREW (GALVANIZED)	ZAPP-M-10 X 10MM	
39	1	PISTON SPRING WASHER (GALVANIZED)	ZAPP-10MM	
40	1	BOLT: SECURING CRANK PULLEY	ZAPP-M10 X 20	
41	8	TIE-ROD NUT	ZAPP-M-8	
42	8	TIE-ROD SPRING WASHER	ZAPP-8MM	
43	1	RELIEF VALVE LOCK-NUT	ZAPP-M16-1,5	
44	1	CONNECTING-ROD LOCK-NUT	ZAPP-M14-1,5	
45	16	WAVEY WASHER	ZAPP-5MM	
46	1	O-RING RELIEF-VALVE PLUG	ZAPP-R-12043	*
47	2	O-RING; PISTON TO ROD	ZAPP-R-2050	
48	4	O-RING VALVE BLOCK - CYL - BLOCK	ZAPP-R-2075	
49	2	O-RING; CYLINDER TO BLOCK	ZAPP-R-3137	
50	1	GRUB SCREW	M6	
51	1	KEY	7 X 8 X 24 LG	
*	1	PUMP MOUNTING CRADLE	ZAPP-401-571	P401168A
*	1	PIVOT PIN (SHOULDER BOLT)	ZAPP-401-572	P401398A
*	1	GREASE NIPPLE	ZAPP-M-6-G	

**PARTS LIST FOR MANUAL FILLING MACHINE
DE-401-GB-AUTO**

- | | |
|--------------------------------|-------------|
| 1. Quick Acting Valve | GCE 661 |
| 2. Scale Beam | |
| 3. Scale Beam adjusting weight | |
| 4. Scale Adjusting Screw | |
| 5. Scale Weight Carrier | |
| 6. Ball Valve | |
| 7. Start/Stop Knob | |
| 8. Flameproof Motor | |
| 9. Coupling | |
| 10. Gear Box | |
| 11. Pump Unit | 10401 PU |
| 12. Proximity Switch | |
| 13. Y-Strainer | |
| 14. Scale | ZAVV-30-SCI |
| 15. Supply Vessel | |
| 16. Duo Valve | GCE-621/622 |
| 17. Manifold and Wall Brackets | |
| 18. Hydraulic Relief Valve | |
| 19. Liquid Pigtail | |

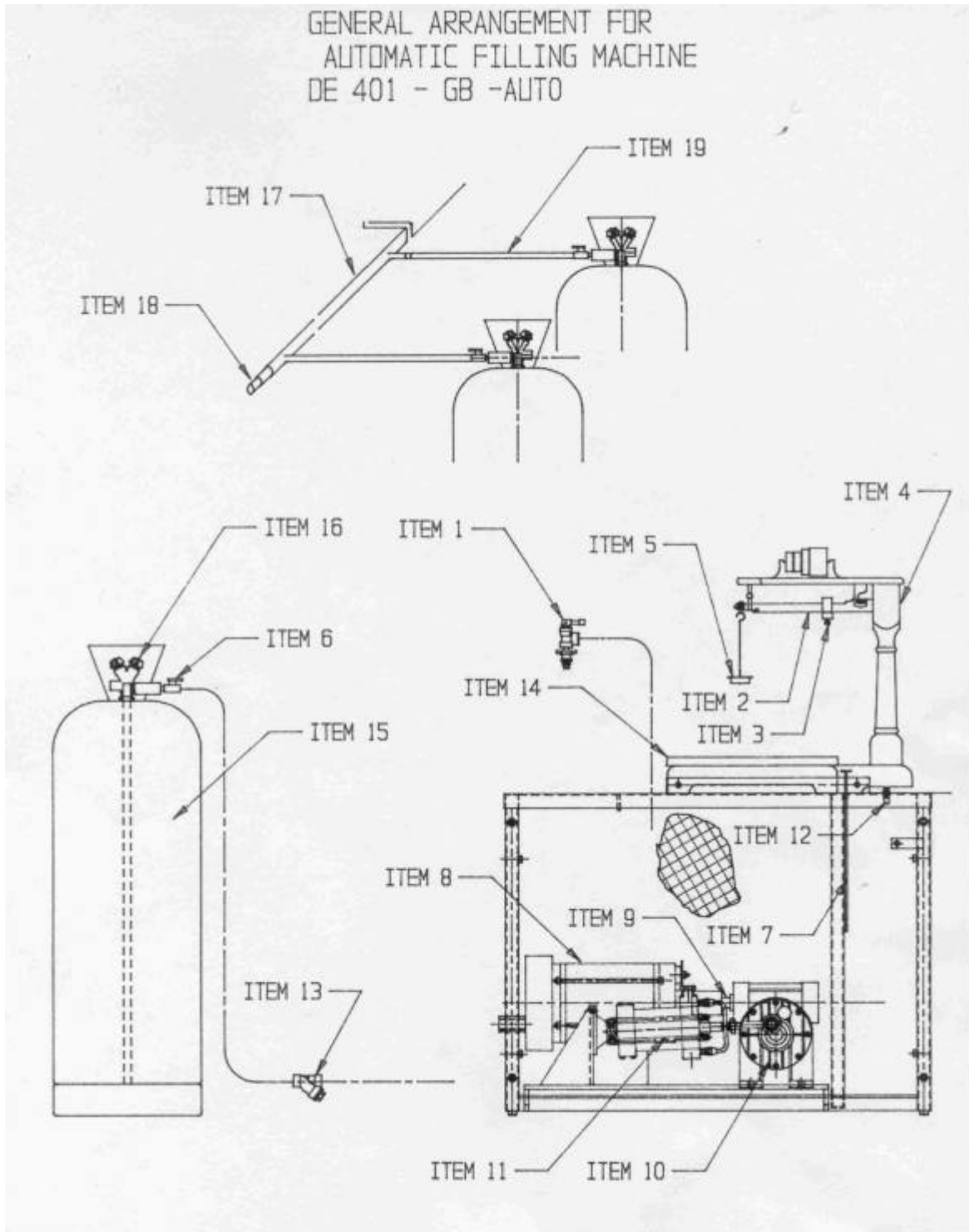

WIRING FOR ALLAN BRADLY MODEL M09 CONTACTOR
 WITH PEPPERL+FUCHS CONTROL MODULE INSTALLED
 IN AN INVERTED POSITION
 (TO ACCOMMODATE EXISTING DIN RAIL POSITION)

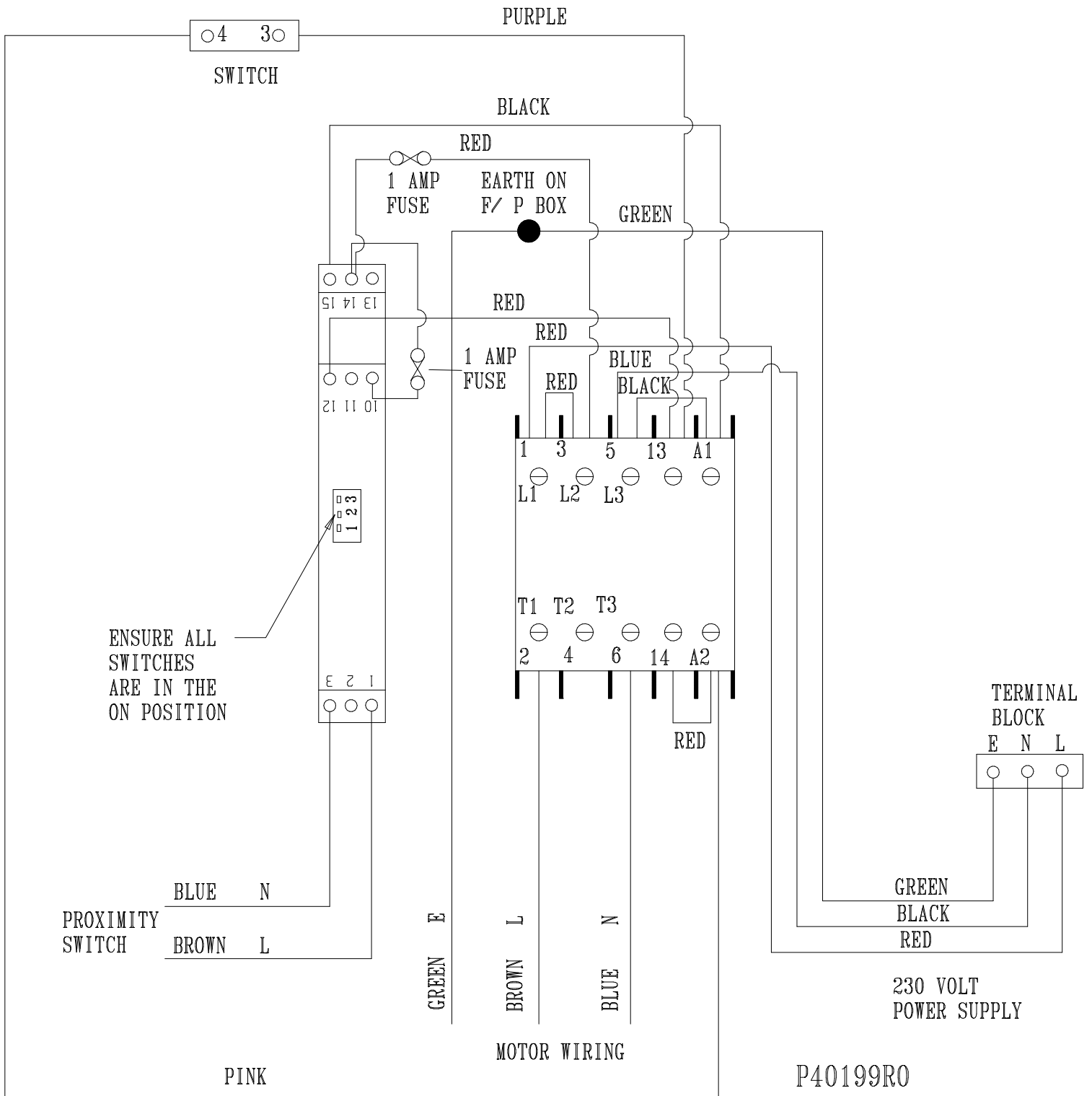

TEST REPORT

1 Dr Lategan Road, Groenkloof
Private Bag X191, Pretoria, 0001
Tel: (012) 428-7911 Fax: (012) 344-1568
Int. code +27 12
Website: www.sabs.co.za



Your ref:
Our ref: 3432/P1034(R)
Enquiries: F du Toit
Tel: (012) 428-6376
Fax: (012) 428-6854
Date: 2 August 2002

Adceng Gas Equipment (Pty) Ltd
PO Box 5413
J OHANNESBURG
2000

REVISED SABS TEST REPORT NO: 3432/856520/P1034(R)
Page 1 of 2

CYLINDER FILLING PUMPS

SUBJECT

The examination of a range of cylinder filling pumps for compliance with SABS 314-1:1994 "Flameproof enclosures for electrical apparatus, Part 1: International requirements".

2. DESCRIPTION

- 2.1 **GENERAL.** The cylinder filling pumps were used to pump liquid LPG. A pump consisted of a certified flameproof Franklin 0,37 kW motor (SABS test report 787/82127/G207) or flameproof FEMCO 0,37 kW motor (SABS test report No. 777/87096/M259) driving a double-action piston pump via a reduction gearbox.

Model DE-401-AUTO is fitted with a flameproof Coaltech CT160 terminal box, Ex d I/IIB T3, GME No VM1234 or a flameproof ADCENG pump box, Ex d IIB T6, IA No. SABS S/W424.

- 2.2 **IDENTIFICATION.** The units were identified by the following marking on the pump casing:

Adceng logo
SABS Cert. mark
Cylinder filling pump
Model DE-401-GB, DE-401-MAN, DE-401-AUTO or DE-402-ELECTR Serial No
220 volt Ex d IIA T3
SABS S/P1034

- 2.3 **DOCUMENTATION.** The following Adceng Gas Equipment (Pty) Ltd GA drawings plus referenced drawings gave details of the cylinder filling pumps:

/No GE0022

SABS affiliated

This report relates only to the specific sample(s) tested as identified herein. It does not imply SABS approval of the quality and/or performance of the item(s) in question and the test results do not apply to any similar item that has not been tested. (Refer also to the complete conditions printed on the back of the official test reports.)

Test House - SABS affiliated company

REPORT No. **3432/856520/P1034R**

Page 2 of 2

No GE0022 Rev 0 dated 1994-07-29
No GE0023 Rev 0 dated 1994-07-29
No GE0037 Rev 0 dated 1994-08-04
No GE0038 Rev 0 dated 1994-04-08
No GE2000 Rev 0 dated 1998-01-28

Copies of these drawings were endorsed with the official SABS stamp.

3. SELECTION OF SPECIMEN

The specimen for testing was supplied by the test sponsor.

4. METHOD OF TEST

The specimen and drawings were examined for compliance with the relevant requirements of SABS 314-1: 1994.

5. RESULTS

No features contrary to the design and constructional requirements of SABS 314-1: 1994 were observed.

6. CONCLUSIONS

The cylinder filling pump as described in paragraph 2 of this report and in the condition as tested, is flameproof, group IIB, temperature class T3 according to SABS 314-1:1994.

It may be used in Zone 1 hazardous locations on surface.

7. VALIDITY OF THIS REPORT

Any modification to the assembly, will invalidate this test report.

As Adceng Gas Equipment (Pty) Ltd is a SABS permit holder for the manufacture of flameproof cylinder filling pumps, this report covers all units as described in this report and manufactured under the SABS approved quality system.



**JG Gagiano: SENIOR TEST OFFICER
EXPLOSION PREVENTION TECHNOLOGY**



R Viljoen MANAGER