

**OPERATING INSTRUCTIONS  
AND PARTS LIST  
HAND OPERATED LPG PISTON  
PUMP WITH SCALE  
301-DH-SP**



**ADCENG GAS EQUIPMENT (PTY) LTD**

[www.adceng.co.za](http://www.adceng.co.za)

**P O BOX 5413, JOHANNESBURG 2000**

**Phone: 011 493-8209**

**Fax: 011 493-1459**

**Email: [adceng@mweb.co.za](mailto:adceng@mweb.co.za)**

**P O BOX 83, PAARDEN EILAND 7420**

**Phone: 021 511-6671**

**Fax: 021 511-4891**

**Email: [adcct@mweb.co.za](mailto:adcct@mweb.co.za)**

**P O BOX 74225, ROCHDALE 4034**

**Phone: 031 579-1555**

**Fax: 031 579-1563**

**Email: [adcdbn@mweb.co.za](mailto:adcdbn@mweb.co.za)**

## **MODEL 301 – DH-SP DOUBLE ACTING HAND OPERATED LPG PUMP WITH SCALE**

### **GENERAL**

The filling unit as shown on the attached drawing is intended for retail outlets and other similar LP-Gas filling sites which fill small containers up to 9 Kg capacity. All the equipment incorporated in this unit is approved for liquid LP-Gas service and meets the requirements of SABS Specification SANS 10087 Part 7 as amended. The installation has to be made according to this code of practice.

The small platform scale is Assize-approved, and of robust construction to withstand the weighing and filling of steel containers under working conditions. The scale has been specially prepared for filling of gas containers. It will ensure the filling of these small containers to within a close margin of the allowable filling mass, provided that the filling operation is carried out by a properly trained person.

No allowance will have to be made for the mass of the filling hose and valve, by setting the scale at zero whilst the hose and quick acting valve are resting on the platform of the scale. The hose must be full of gas up to the quick-acting valve (1) when doing the setting.

Approximate filling times for the various small containers at 25 strokes per minute are as follows:

|                  |         |
|------------------|---------|
| 1,3 Kg container | - 1 min |
| 3 Kg container   | - 2 min |
| 4,5 Kg container | - 3 min |
| 6 Kg container   | - 4 min |

### **PRINCIPLE OF OPERATION:**

Product enters the cylinder of the pump below and above the piston through inlet valves, as long as the receiving vessel is at a lower pressure, passes through it into the outlet valves.

When the pressure between the vessels equalises, flow will cease, and the entire system will be at supply vessel pressure. Since this pressure acts equally above and below the piston in the pump, no force is exerted on the handle (except for a very small amount due to the piston rod displacement).

During operation the velocity of flow into the pump is equal to the velocity of delivery, thus there is no rapid reduction of pressure in the suction line which would cause liquid to flash into vapour. Vapour would adversely affect pumping efficiency, since the piston merely tends to compress it instead of expelling it, leaving it to re-expand on the following stroke.

To cope with vapour problems the pump is specially designed to have a minimum of (clearance loss), however this presupposes that full up and down strokes are applied.

**ADDITIONAL FEATURES:**

The pump unit is completely protected against corrosion. Piston and piston rod seals are easily replaceable. All other sealing is by O-rings. There are no gaskets. The piston rod guide bush is of Vesconite which also acts as a seal keeping out all impurities.

The automatic ball valves offer virtually no resistance to the flow of product from supply vessel to the small container, thus permitting gravitational transfer.

This reduces the amount of pumping required considerably.

## **OPERATING INSTRUCTIONS FOR 301-DH-SP DOUBLE ACTING HAND OPERATED LPG PUMP WITH SCALE**

### **FILLING MUST BE UNDERTAKEN BY A SUITABLY TRAINED OPERATOR**

- A. Connect the inlet hose flare nut (2) to the liquid outlet of the supply container valve (duo valve). Do not open the inlet valve yet.
- B. Open ball valve (3) on inlet hose.
- C. Ensure that the filling hose up to the quick acting valve (1) is filled with liquid before venting the air out of the hose. Now place the hose and quick acting valve on the platform of the scale. The beam (2) should be in equilibrium with the sliding weight (3) at zero.
- D. If the scale is not in equilibrium, turn the screw (4) at the back of the beam in or out using a screw-driver. This will adjust the beam to the required position.
- E. Place the small cylinder to be filled on the scale platform and connect the quick acting valve (1) to the small container valve. Use the appropriate filling adapters to suit the cylinder being filled.
- F. Calculate the appropriate filling mass, i.e. (tare mass plus container capacity) and set the weight on the carrier (5) of the scale.
- G. Open the ball valve (6) the small container valve and quick acting valve (1).
- H. Open liquid filling supply container valve (red handle on duo valve) slowly to prevent closing of excess flow valve inside the supply container. Liquid will now flow through the inlet hose into the hand pump and the small container until the pressure between the two containers is equalized. Should the excess flow valve snap shut (indicated by an audible click) it must be released by re-closing the supply container and waiting for a few second until another click is heard. The supply valve must then be opened just slightly until the initial rush of liquid through it is heard to slow down after which it may slowly be fully opened. When the pressure begins to equalize the flow of liquid will be heard to slow down.
- I. Then operate hand pump with full up and down strokes until scale indicates that the maximum filling mass has been reached.
- J. Stop pumping immediately and close quick acting valve (8).
- K. Close the small container valve and disconnect the quick acting valve (1) from the small cylinder which is now full.
- L. If cylinder filling operations are complete then close the liquid withdrawal valve (red). Do not close the ball valve until the supply container is to be removed.

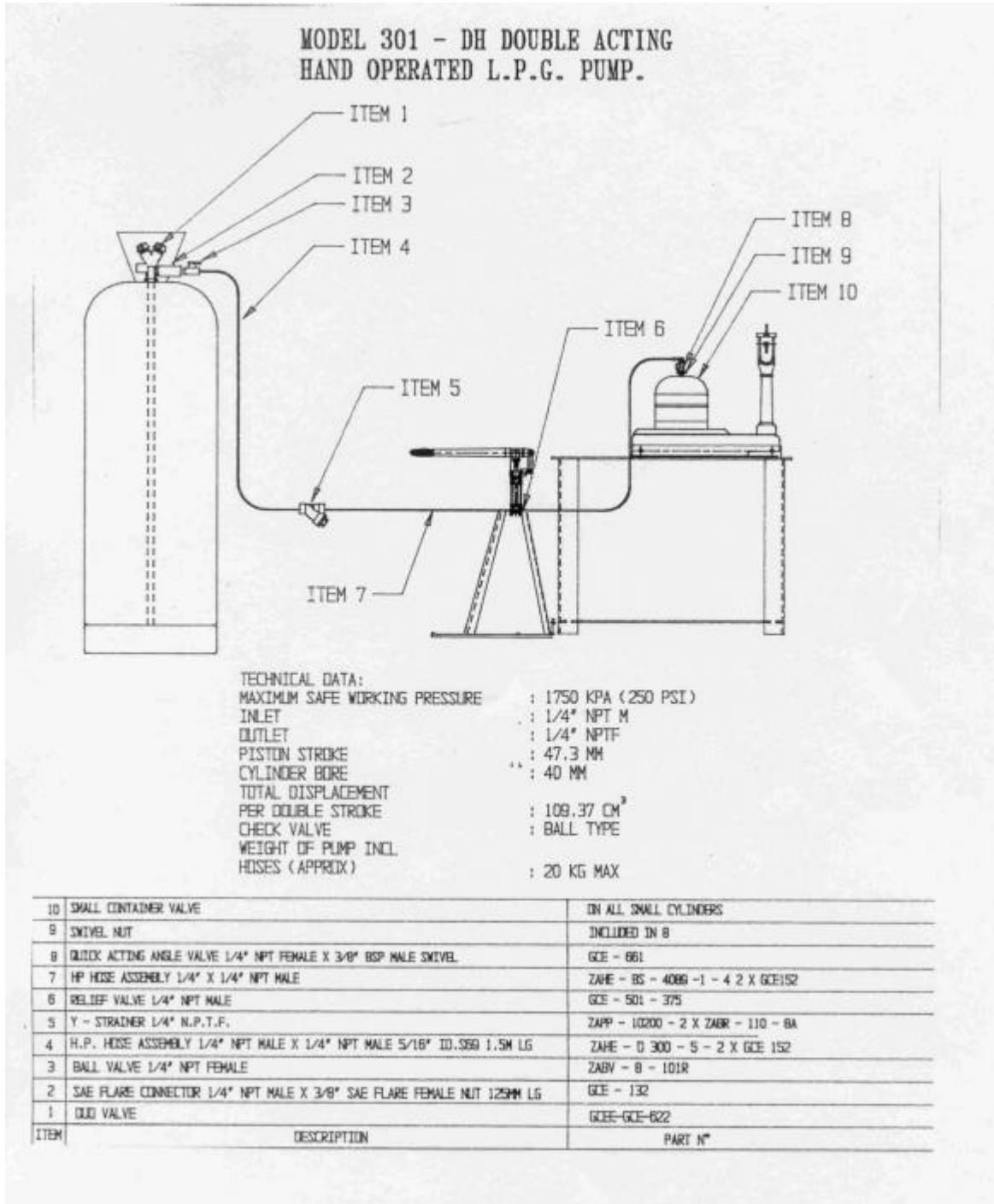

GENERAL ARRANGEMENT FOR  
MODEL 301 - D  
DOUBLE ACTING HAND LEVER PUMP

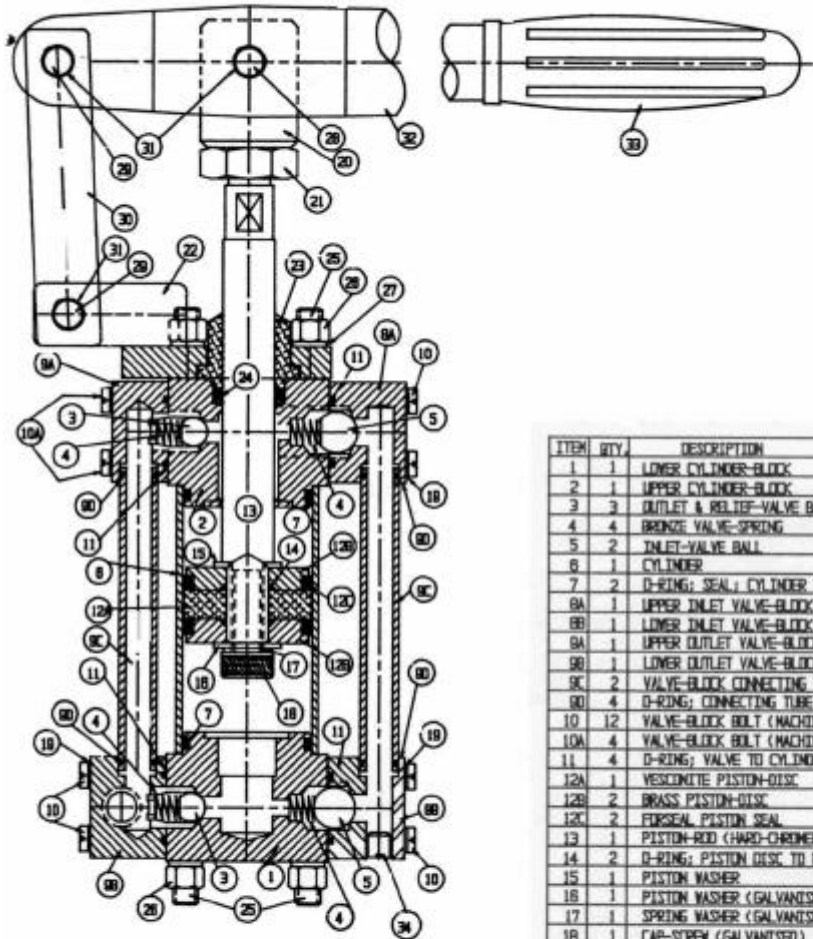

| ITEM | QTY | DESCRIPTION                         | PART No.        | DWG N°    |
|------|-----|-------------------------------------|-----------------|-----------|
| 1    | 1   | LOWER CYLINDER-BLOCK                | ZAPP-401-DE-501 | P40139RA  |
| 2    | 1   | UPPER CYLINDER-BLOCK                | ZAPP-401-DE-502 | P40130RA  |
| 3    | 3   | OUTLET & RELIEF-VALVE BALL          | ZAPP-101-011    |           |
| 4    | 4   | BRONZE VALVE-SPRING                 | ZAPP-101-014    |           |
| 5    | 2   | INLET-VALVE BALL                    | ZAPP-101-015    |           |
| 6    | 1   | CYLINDER                            | ZAPP-401-DE-504 | P40144RA  |
| 7    | 2   | O-RING; SEAL; CYLINDER TO BLOCK     | R3137           |           |
| 8A   | 1   | UPPER INLET VALVE-BLOCK             | ZAPP-401-513A   | P40139RA  |
| 8B   | 1   | LOWER INLET VALVE-BLOCK             | ZAPP-401-513B   | P40131RA  |
| 8A   | 1   | UPPER OUTLET VALVE-BLOCK            | ZAPP-401-522A   | P40129RA  |
| 8B   | 1   | LOWER OUTLET VALVE-BLOCK            | ZAPP-401-512B   | P40134RA  |
| 9C   | 2   | VALVE-BLOCK CONNECTING TUBE         | ZAPP-401-514    | P40125RA  |
| 9D   | 4   | O-RING; CONNECTING TUBE             | ZAPP-401-515    | Ø X 1.5   |
| 10   | 12  | VALVE-BLOCK BOLT (MACHINE SCREW)    | ZAPP-401-DEH    | M5 X 30   |
| 10A  | 4   | VALVE-BLOCK BOLT (MACHINE SCREW)    | ZAPP-401-DEH    | M5 X 25   |
| 11   | 4   | O-RING; VALVE TO CYLINDER-BLOCK     | R 2075          |           |
| 12A  | 1   | YECOMITE PISTON-DISC                | ZAPP-401-506V   | P40117RA  |
| 12B  | 2   | BRASS PISTON-DISC                   | ZAPP-401-506B   | P40126RA  |
| 12C  | 2   | FURSEAL PISTON SEAL                 | ZAPP-401-506J   |           |
| 13   | 1   | PISTON-ROD (HARD-CHROMED)           | ZAPP-401-506H   | P40120RA  |
| 14   | 2   | O-RING; PISTON DISC TO ROD          | R 2050          |           |
| 15   | 1   | PISTON WASHER                       | ZAPP-401-518    | M13 X 1.8 |
| 16   | 1   | PISTON WASHER (GALVANISED)          | ZAPP-401-557    | M10 X 1.8 |
| 17   | 1   | SPRING WASHER (GALVANISED)          | ZAPP-10HM       | M10       |
| 18   | 1   | CAP-SCREW (GALVANISED)              | ZAPP-M10X16     | M10 X 16  |
| 19   | 16  | NAVY WASHER (OR "STAR" WASHER)      | ZAPP-5HM        | M5        |
| 20   | 1   | CROSS-HEAD                          | ZAPP-401-563    | P40183RD  |
| 21   | 1   | LOCK-NUT (CROSS-HEAD TO PISTON-ROD) | ZAPP-M14X1.5    | M14 X 1.5 |
| 22   | 1   | BUSH-RETAINING CAP WITH LEVER PIVOT | ZAPP-401-556    | P40122RA  |
| 23   | 1   | YECOMITE PISTON-ROD BUSH            | ZAPP-401-DE-510 | P40118RA  |
| 24   | 1   | FURSEAL PISTON-ROD SEAL             | ZAPP-401-518J   |           |
| 25   | 4   | TIE-ROD                             | ZAPP-401-557    | P40150RA  |
| 26   | 12  | TIE-ROD NUT                         | ZAPP M - 8      | M8        |
| 27   | 8   | SPRING WASHER                       | ZAPP-6HM        | M8        |
| 28   | 1   | LONG PIVOT-PIN                      | ZAPP 301-016    | P40180RD  |
| 29   | 2   | SHORT PIVOT-PIN                     | ZAPP 301-015    | P40181RD  |
| 30   | 2   | LINK-LEVER                          | ZAPP-401-561    | P40183RD  |
| 31   | 8   | CIRCLIP                             | ABLE-471-10HM   | Ø 10      |
| 32   | 1   | HANDLE                              | ZAPP-401-569    | P40173RD  |
| 33   | 1   | RUBBER HAND-GRIP                    | ZAPP-401-565    |           |
| 34   | 1   | 1/8" N.P.T. PLUG                    | ZAPP-10G-2      |           |

DRAWING NO. C00030R0

**FAULT FINDING CHART****301-DH-SP PUMP**

| <b>SYMPTOM</b>               | <b>REMEDY</b>   |
|------------------------------|---|
| A) Pump not pumping          | a) Check suction and discharge valves<br>b) Check piston assembly<br>c) Check LPG supply<br>d) Check hoses for blockages<br>e) Check strainer |
| B) Pump leaking              | a) Check and/or replace o-ring<br>b) Replace top seal   |
| C) Pump not filling cylinder | a) Check hoses for blockages<br>b) Check cylinder<br>c) Check strainer  |
| D) Filling incorrect weight  | a) Check calibration of scale<br>b) Check scale weights<br>c) Check operating procedure   |