

V6000 Dimensions

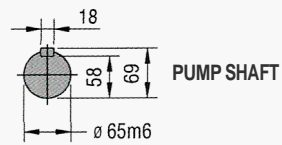

MATERIALS OF CONSTRUCTION

| Cat # | Description | Material | Qty |
|-------|-------------------------------|---|-----|
| 100 | BODY | Ductile Iron or Cast Steel | 1 |
| 101 | LINER | Cast Iron | 1 |
| 102 | ROTOR ON SHAFT | Ductile Iron/Stainless Steel | 1 |
| 107 | WEARPLATE | Cast Iron | 2 |
| 111 | VANES | Univare | 6 |
| 115 | PUSHRODS | Unirod | 6 |
| 116 | BODY KEY | Key Steel | 1 |
| 200 | BEARING HOUSING | Ductile Iron or Cast Steel | 2 |
| 201 | BODY COVER | Ductile Iron or Cast Steel | 2 |
| 202 | DUST CAP (DRIVE END) | Ductile Iron | 1 |
| 203 | O-RING (DUST CAP) | Nitrile | 2 |
| 204 | ROLLER BEARING | Commercial | 2 |
| 207 | LOCKNUT | Mild Steel | 2 |
| 213 | LOCKNUT (ADAPTOR SLEEVE) | Mild Steel | 2 |
| 302 | DUST CAP - INSPECTIONEND | Ductile Iron | 1 |
| 500 | MECHANICAL SEAL ASSEMBLY | Seal Faces available: SiC, TC, Carbon Elastomers: Nitrile, Viton, Kalrez or PTFE | 2 |
| 511 | OIL SEAL (BEARING HOUSING) | Nitrile | 2 |
| 512 | OIL SEAL (DUST CAP DRIVE END) | Nitrile | 1 |
| 515 | O-RING (BODY COVER) | Nitrile or Viton | 2 |
| 522 | O-RING (BEARING HOUSING) | Nitrile or Viton | 2 |
| 525 | THROTTLE BUSH | Bronze | 2 |
| 618 | COUPLING KEY | Key Steel | 1 |

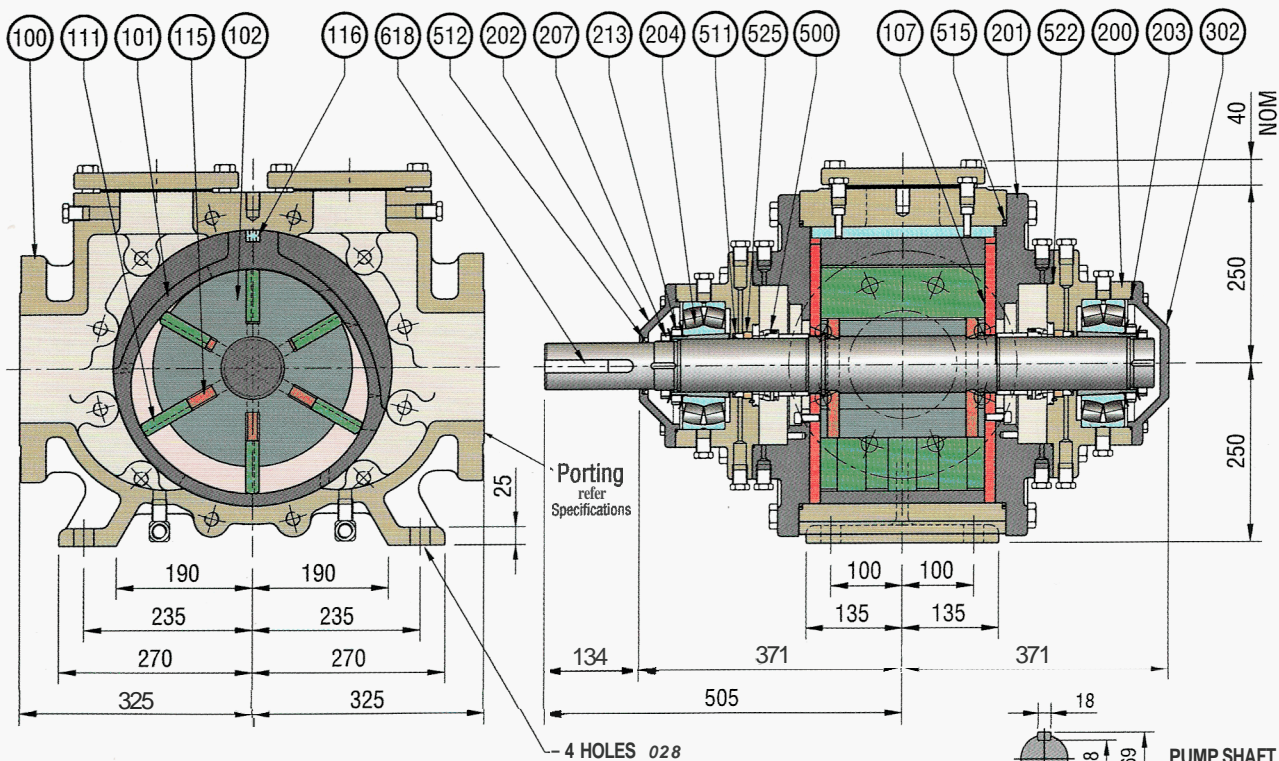
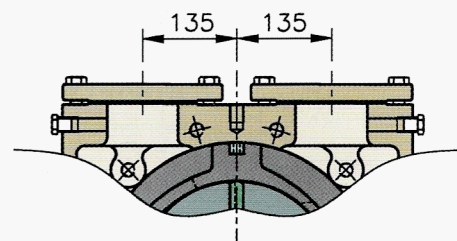

Optional alternate Bypass/Outlet ports to suit DN 100 (4") ANSI CLASS 150. Available with with certain configurations only. Refer EBSRAY.

Other materials are available to suit almost any application. Please contact your EBSRAY Representative.